

# Pushover Analysis of Harvard Dormitory Thursina International Islamic Boarding School Building with Inter Story Isolated System Modification

Aulia Rahman<sup>1\*</sup>, Anisah Nur Fajarwati<sup>2</sup>, Moch. Sholeh<sup>3</sup>, Agus Sugiarto<sup>4</sup>

<sup>1234</sup> Civil Engineering Department of State Polytechnics of Malang

Email: <sup>1\*</sup> aulia.rahman@polinema.ac.id, <sup>2</sup> anisah\_nur\_f@polinema.ac.id, <sup>3</sup> moch.sholeh@polinema.ac.id, <sup>4</sup> agussugiarto1030@gmail.com

DOI: <https://doi.org/10.31284/j.jtm.2025.v6i1.6283>

Received 23 July 2024; Received in revised 4 November 2024; Accepted 5 November 2024; Available online 13 January 2025

Copyright: ©2025 Aulia Rahman, Anisah Nur Fajarwati, Moch. Sholeh, Agus Sugiarto

License URL: <https://creativecommons.org/licenses/by-sa/4.0>

## Abstract

Recently the demands of additional building functions have varied. These demands tend to affect structure stability because of the effects of additional mass. For example, Harvard Dormitory Thursina International Islamic Boarding School, located in Dau region, Malang city, East Java, Indonesia, a 11 x 8 m<sup>2</sup> swimming pool is relocated on 4<sup>th</sup> floor. A big mass of pool certainly performs bigger lateral force due to seismic behaviour of structure itself. To reduce that, the IIS method is installed on the 3rd floor as it has damper effect along X and Y axis that is provided by LRB spring systems. IIS is widely used mainly in Japanese high-rise structures such as Shiodome Sumitomo building and Umeda Tower. To analyse the IIS modified structure, it is performed pushover analysis as controlled deformation is stated 18 in at rooftop. The results showed that 465 kN shear force and 160 mm story drift occurred on the 3rd floor which is the largest value compared to other stories. It is also obtained 230 mm lateral deflection of rooftop as the first plastic hinges are formed.

**Keywords:** seismic, pushover, deformation, IIS metode

## 1. Introductions

Recently, various function of building makes facilities are placed and cramped in a single story and this leads to high risk of structure failures. Facilities such as swimming pools, parking areas, machine storages gain an additional superimposed dead load. These extra concentration of masses affect amounts of lateral forces due to seismic responses so that structure dilatation and reinforcement should be concerned on several points. Some building stability challenges are also indicated to arise due to additional room functions that are placed in a single floor such as lateral deformation control, rebar redundancy, and concrete element oversized. The same case applied in project of Harvard Dormitory Thursina International Islamic Boarding School that is located in Dau region, Malang. The swimming pool that is previously planned in level 2, moved into level 4 as depicted at **Figure 1**.



**Figure 1. Harvard Dormitory Thursina International Islamic Boarding School**

One of methods to reduce the damage of amplified seismic load is installation of inter-story isolated structures (IIS) that is basically damper tools to control dilatation between stories.[1] IIS is widely used at multi stories building since the limitation of base isolation system. With IIS, building engineers can derive the functions of building into two characteristics which are upper structure that is relatively not affected by earthquake loads and lower structure that provides bigger stiffness. It also gives architects a better flexibility in designing the function of building because they can derive two characteristics of building that different to each other.[2] This method also tends to be applied in irregularly vertical shaped building.[3] Some high rised building in advanced countries also implemented this methods for example, Shiodome Sumitomo building [4] (**Figure 2**), and Umeda Tower [5] that both of those are located in Japan. For US, there are 185 Berry Street Building, in San Francisco, that installed the same tools in the stories [6]



**Figure 2. The installation of IIS in Shiodome Sumitomo Building [7]**

IIS method is theoretically a system of impulse damper that is illustrated in **Figure 3**. Notation of  $m_b$  and  $x_b$  are represented the mass and damper transformation, as for  $m_1 - m_n$  are the mass,  $k_1 - k_n$  are stiffness, and  $c_1 - c_n$  are damping coefficient in each upper level. As for  $x_1 - x_n$  are dilatations from base. Generally, the stiffness below IIS are made bigger than the upper ones that movements above are linearly assumed despite IIS could move unlinearly. So, the relationship between mass, stiffness, damping factors, and dilatations can be satisfied by **eq 1** [8].

$$M\ddot{x} + C\dot{x} + Kx + f(x, \dot{x}) = -Mr\ddot{x}_g \tag{1}$$

If  $y_1 = x_i - x_{i-1}$  so the equation can be rewritten as,

$$\hat{M}\ddot{y} + \hat{C}\dot{y} + K_s y + K_z z = -Mr\ddot{x}_g \tag{2}$$

Because relative transformations of upper structure of IIS can be ignored, so koppel effects on damper also can be assumed not exist so that the equations can be represented as,

$$m_b \ddot{y}_b + c_b \dot{y}_b + \alpha k_0 y_b + (1 - \alpha)k_0 z = -m_b \ddot{x}_g \tag{3}$$

If the seismic effects are considered, so **eq 2** should be converted linearly by using equivalent linearization methods. Assume initial dilatation with  $D$  so that stiffness ( $k_{b,eq}$ ) and equivalent damping factor ( $\zeta_{b,eq}$ ) can be approached by **eq 4** [9],

$$k_{eq,b} = \frac{k_y(D-d_y) + k_o d_y}{D}$$

$$\xi_{eq,b} = \frac{2f_y(D-d_y)}{\pi.k_{eq,b}D^2} \quad (4)$$

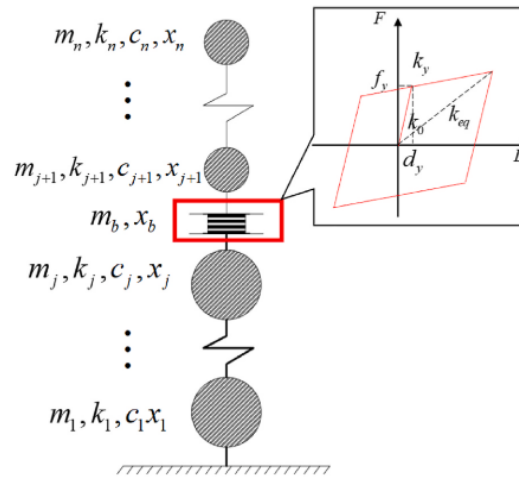

Figure 3. Finite model of IIS [9]

Inter stories damper is made of elastomeric based material. The tool that usually can be found in beam bridge support is widely used since first time found in 1950's. Its characteristic is well designed to bear vertical loads, having low stiffness, and ability to maintain its shape.[10] One of most used model of the damper is lead-plug rubber bearing (LRB) because the formidable capacity of dissipation energy, endurance of shear force, ability to reduce vertical displacement, and damper ratio up to 30%. LRB is made of layered latex with *steker* as the core, like illustrated by Figure 4 [11], [12], [13].

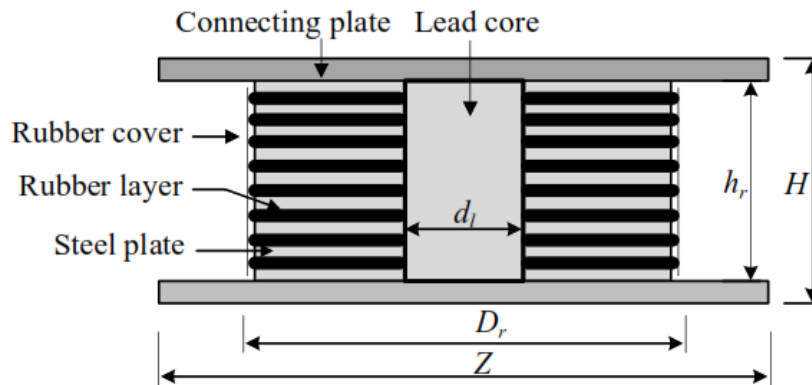
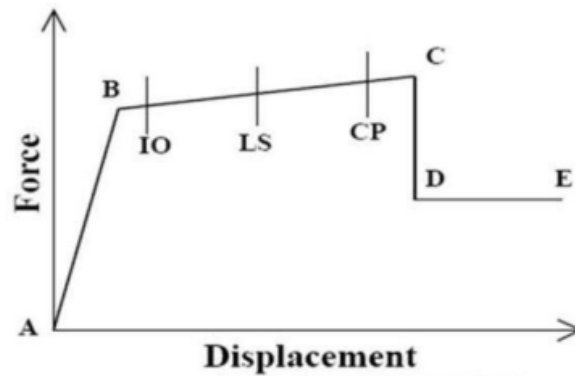

Figure 4. Illustrated LRB [10]

Another method used to analyse response of the structure due to lateral seismic load is pushover analysis. Basically, pushover is the addition of horizontal static loads that is increased gradually with factors to obtain targeted dilatation. Moreover, pushover is also used to pinpoint plastic hinges on the structure as the failures conduct. As the result of shear forces, deformations, and plastic hinges, this method is basically the simplification of seismic load to detect which parts of the structure tend to fail when the earthquake happend. [14] The appearance of plastic hinges is also represented the limitations of building design, as depicted in Figure 5, which are immediate occupancy (IO), life safety (LS), and collapse prevention (CP) [15]



**Figure 5. Forces vs deformations in performance based approach**

Thus, after considering all of those, in this scientific writings, Harvard Dormitory Thursina International Islamic Boarding School is remodelled using BIM (*Building Information Modelling*), then IIS is applied to reduce additional lateral load that is caused by replacement of swimming pool into fourth level. The response of the structure will be analysed using pushover method.

**2. Methods**

Five stories of analysed building is remodelled as the detailed dimension of beams, columns, and reinforcement rebars are presented in **Table 1**. The used structure application is Etabs 20 with pushover is generated as simplification of lateral seismic loads. Pushover method is selected to evaluating the effects of the relocated swimming pool of Harvard Dormitory because basically the main issue to discuss is lateral deformations that are caused by earthquake loads so that the ultimate deformation as the first occurred plastic hinge can be proposed. As for the mass addition is swimming pool with dimension of 11 x 8 m<sup>2</sup> that illustrated in **Figure 6**.

**Table 1. Beam dimensions and reinforcement rebars**

BEAM		B (cm)	H (cm)	As min		As used		CHECK	
				A (cm <sup>2</sup> )	ratio	Ø/ D	n Ø/ D		
SL24	Joint	20	40	3,5	2,63	13	3	13	OK
	Mid				2,86				
SL35	Joint	30	50	11	3,87	19	4	19	OK
	Mid				4,01				
B24	Joint	20	40	4	3,01	13	3	13	OK
	Mid				2,41				
B25	Joint	20	50	3,1	2,33	13	3	13	OK
	Mid				3,01				
				4	2	13	3	13	OK

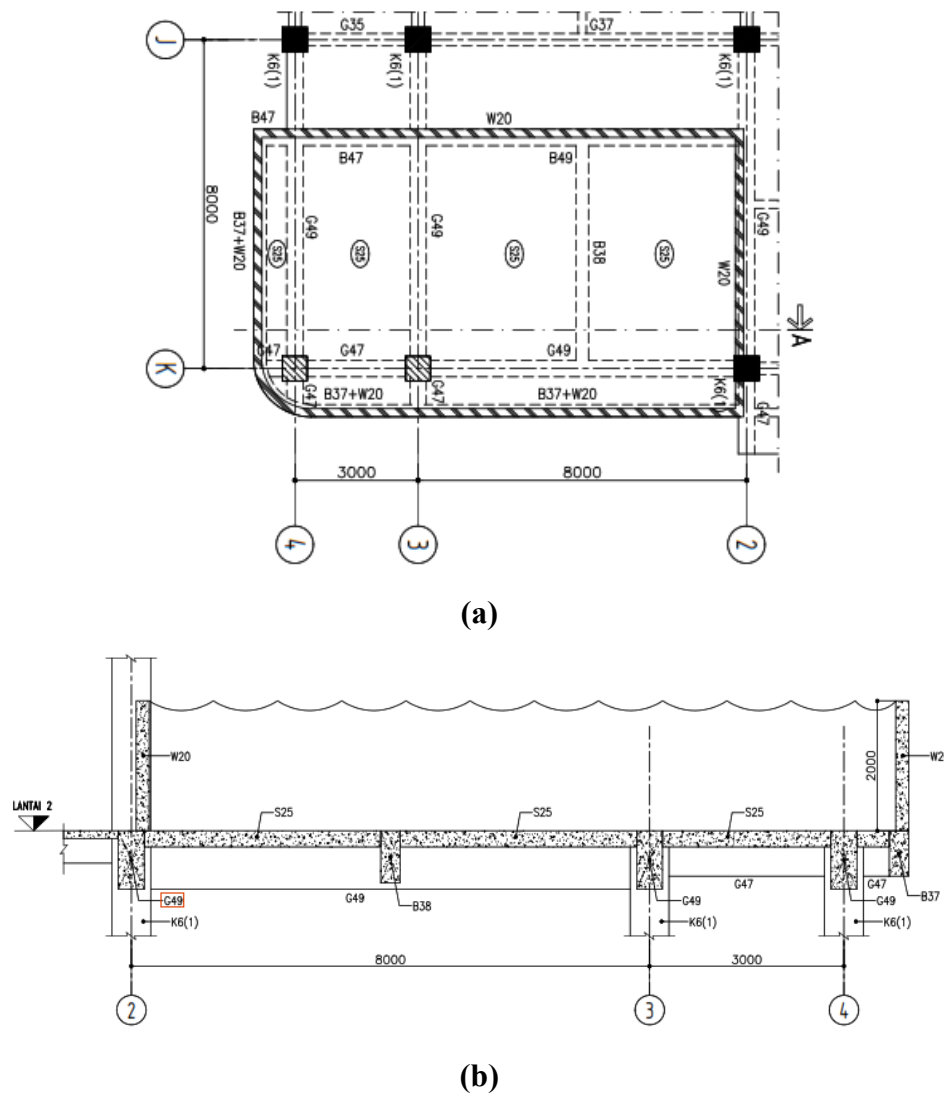

Figure 6. (a) Swimming pool plan (b) Swimming pool section

As for isolator to reduce the lateral response, it is placed in columns of third floor, with specifications presented in Table 2. All of those are based on UBC 97, with the load distributions are concentrated in internal columns.

Table 2. Specs of LRB as IIS at third floor

Specs	Value	Unit
Rotational inertia	0.016603	kN/m
Effective stiffness of U1 axis	1175418,57	kN/m
Effective stiffness of U2 and U3 axis	1175,42	kN/m
Effective damper factor of U2 and U3 axis	0,05	-
Distance to column joint	0,00318	m
Effective stiffness of U2 and U3 axis	10831	kN/m
Yield strength of U2 and U3 axis	34,70	kN

The analysed building is located in Dau region, Malang, so that the soil condition is medium (SD), with another seismic parameters are presented in Table 3. While, the response spectrum graph are shown in Figure 7.

**Table 3. Soil parameters of Dau region, Malang**

Variable	Value	Variable	Value
PGA (g)	0,399	A <sub>0</sub>	0,208
SS (g)	0,781	PSA (g)	0,399
S1 (g)	0,33	S <sub>MS</sub> (g)	0,781
CRS	1,003	S <sub>M1</sub> (g)	0,33
CR1	0,921	S <sub>DS</sub> (g)	0,521
FPGA	1,00	S <sub>D1</sub> (g)	0,22
FPGA-M	0,399	T <sub>0</sub>	0,085
Fa	1,00	T <sub>s</sub>	0,423
Fy	1,00		

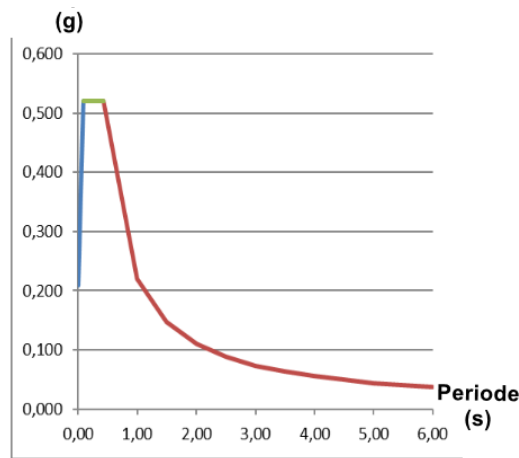
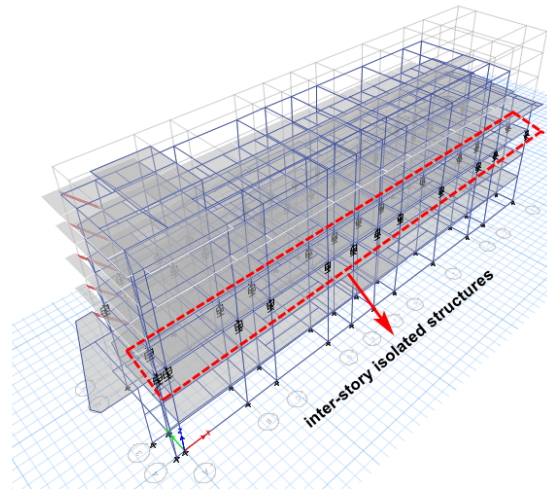

**Figure 7. Response spectrum of Dau region, Malang**

As for mass participations and shear forces are represented in **Table 4**. The 3D view of remodelled building is shown in **Figure 8**.

**Table 4. Recap of lateral force distribution and building weight per level**

Floor	h <sub>i</sub> (m)	h <sub>x</sub> (m)	h <sup>k</sup> <sub>x</sub>	W <sub>x</sub> (kg)	W <sub>x</sub> h <sup>k</sup> <sub>x</sub>	C <sub>vx</sub>	F <sub>y</sub> (kg)	F <sub>y</sub> (kg) cum	F <sub>y</sub> (kg) dinamic	Scale Up	F <sub>y</sub> (kg) design	F <sub>y</sub> (kg) distribution
7	3.00	23.00	529	33,060	17,488,939	0.025	4,019	4,019	2,428	4,547	4,547	4,547
6	3.50	20.00	400	531,513	212,605,177	0.298	48,857	52,876	21,064	39,450	52,876	48,329
5	4.00	16.50	272	758,604	206,530,031	0.290	47,461	100,336	39,637	74,236	100,336	47,461
4	4.00	12.50	156	1,145,055	178,914,793	0.251	41,115	141,451	58,136	108,882	141,451	41,115
3	4.00	8.50	72	882,286	63,745,171	0.089	14,649	156,100	68,490	128,275	156,100	14,649
2	4.00	4.00	16	939,485	15,031,759	0.021	3,454	159,554	79,054	148,059	159,554	3,454
1	4.50	4.50	20	904,715	18,320,481	0.026	4,210	163,764	87,439	163,764	163,764	4,210
TOTAL				5,194,718	712,636,351	1.000	163,764					163,764



**Figure 8. 3D model of Harvard Dormitory Thursina International Islamic Boarding School with the addition of IIS in third floor**

### 3. Results and discussions

Having pushover analysis performed, with targeted lateral deflection of 18 in, it obtained plotted pushover graph as shown in **Figure 9**. The green line represents relationship between lateral deflection and acceleration that intersect red line which is targeted single demand of FEMA 440 about 230 mm. This value is indicated as the initial failure of the structure that plastic hinges start forming. As for, **Table 5** present the detailed information of displacement and acceleration of that spectral.

**Table 5. Detailed displacements Vs spectral acceleration**

Sd	Sa	Periods
(mm)	(g)	(sec)
0	0	0,89
22,45	0,114172	0,89
60,256	0,198258	1,106
98,513	0,255867	1,245
135,004	0,304508	1,336
180,199	0,361657	1,416
200,772	0,386954	1,445

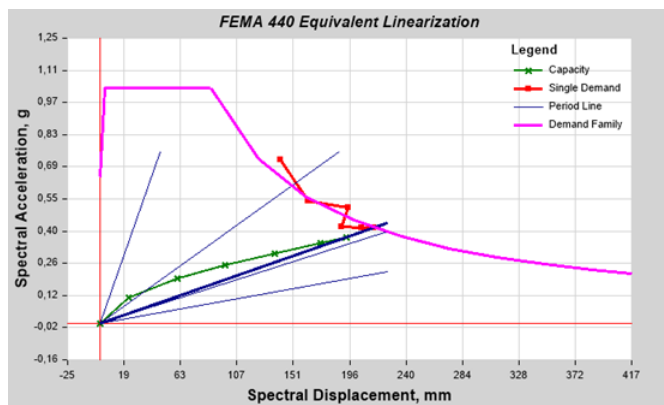
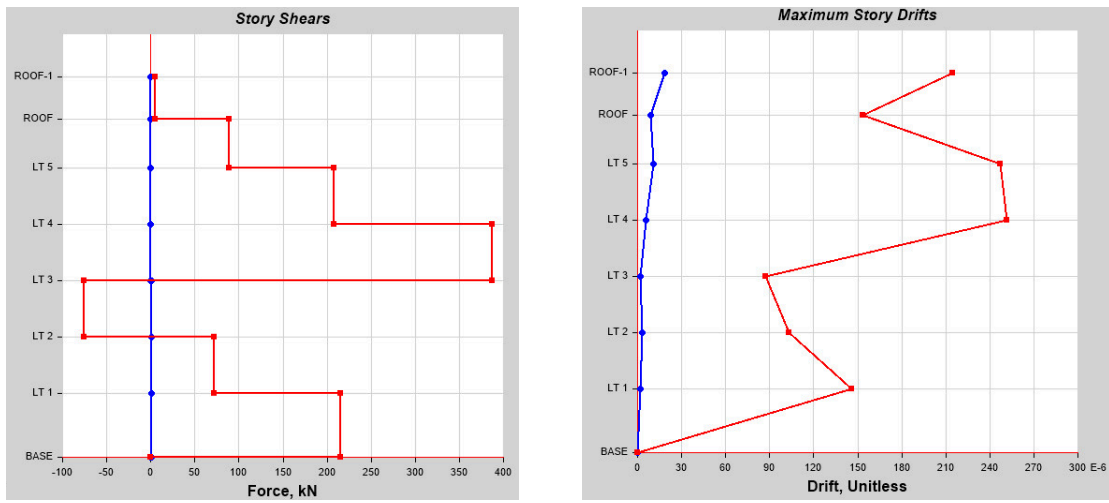

**Figure 9. Plotted pushover lines**

While, the existence of IIS affects the pattern of drift and shear force of each floor, as shown in **Figure 10**. A relatively big gap of shear force can be seen in third floor which is the place where IIS is installed, about 465 kN, as shown in **Figure 10.a**. This is the prove that LRB effect work to endure



the forces. The shear force gap indeed is also followed by drift differences between third and fourth floor, about 160 mm that shown in **Figure 10.b**. The *drift* and shear force value at dominan pushover, which is Y axis, is represented by red line, while X axis is the blue one.



(a) (b)  
**Figure 10 a.) Shear force each floor, b.) Drift each floor**

The appearance of plastic hinges are visible when the pushover reached 5 steps for Y direction and 16 steps for X direction, however none of those surpass the phase of IO (immediate occupancy), as shown in **Figure 11**. While, neither static lateral force in Y nor X axis cause failure in column joints. The beams and columns above third floor, point of installed IIS, are not damaged significantly due to the forming of plastic hinges until the end of pushover step loading, as shown in **Figure 12** and **Figure 13**. This behavior is indicated as the effect of IIS that make lower structures are more impacted by lateral loads than upper structures. The detailed information regarding value of bending moment and rotational plastic hinges are represented in **Table 6**.

In summary, IIS is proposed to reduce shear force approximately 465 kN in discussed floor gap, and tolerated lateral deformation about 230 mm to form initial failure of plastic hinge.

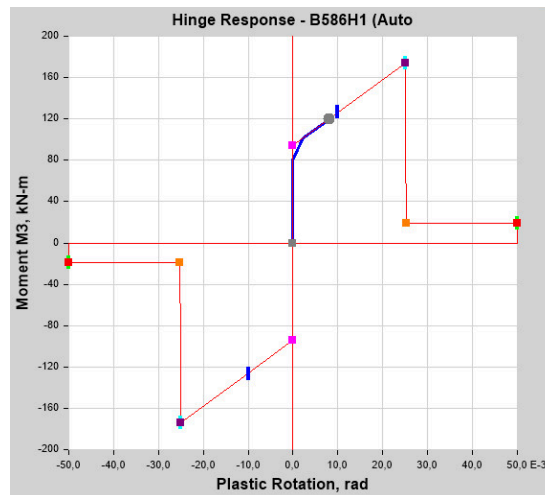

**Figure 11. Plastic hinges conditions**

**Table 9. Detailed value of moment and rotation of plastic hinge for each step**



Steps	M3	R3	R3 Max	R3 Min	Range	Status
	(kNm)	(rad)	(rad)	(rad)		
0	0	0	0	0	A to <=B	A <=IO
1	80,2572	0	0	0	A to <=B	A <=IO
2	101,5454	0,002277	0,002277	0	B to <=C	A <=IO
3	108,0569	0,004314	0,004314	0	B to <=C	A <=IO
4	112,8481	0,005813	0,005813	0	B to <=C	A <=IO
5	118,3313	0,007529	0,007529	0	B to <=C	A <=IO
6	120,7414	0,008283	0,008283	0	B to <=C	A <=IO

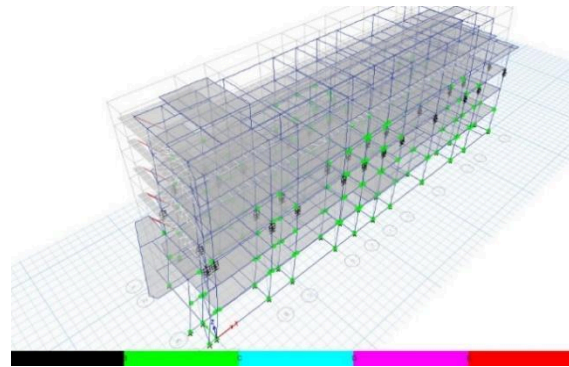

Figure 12. Distribution of plastic hinge in X way pushover

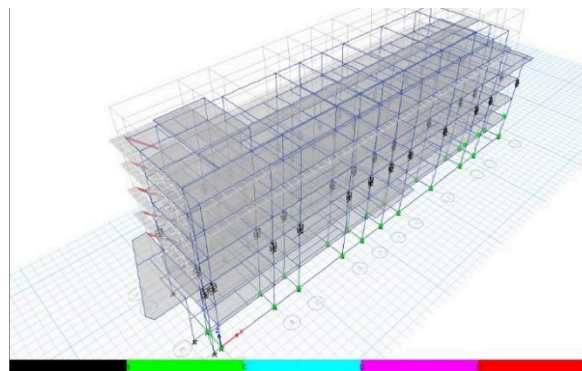

Figure 13. Distribution of plastic hinge in Y way pushover

#### 4. Conclusions

The relocation of swimming pool from third to fourth floor of Harvard Dormitory Thursina International Islamic Boarding School indeed makes the targeted floor gains additional load which is about 1,145,055 kg with lateral load due to seismic response reaches 141,451 kg. This condition needs to be reduced by installation of LRB typed IIS, with lateral stiffness about 1175418,57 kN/m in third floor as seismic damper. Having performed pushover analysis with targeted displacement of 18 in, or about 457,2 mm at highest point of building, the structure performed a relatively big shear force and drift gap at third floor, which is about 465 kN and 160 mm.

Another effect that can be observed as the results of pushover loadings is the furthest displacement before first plastic hinge formed is about 230 mm. As for, the formed plastic hinges are still in range of IO condition, either caused by pushover in X or Y direction until last step of loadings, with the value of moment and rotation of 120,7414 kNm and 0,008283 rad respectively. The distributions of plastic hinges after final step of pushover loadings also spread beneath the level of installed IIS, which is under third floor. So that, IIS method is responsible in reducing seismic load in the term of inter story shear force decrease and deformation control.

## References

- [1] M. Ismail, "Seismic isolation of structures. Part I: Concept, review and a recent development," *Hormigón y Acero*, vol. 69, no. 285, hlm. 147–161, Mei 2018, doi: 10.1016/j.hya.2017.10.002.
- [2] P. Thakur, S. K. Sethy, dan M. K. Dubey, "Review Paper on Inter Story Isolation System," *International Journal of Research in Advent Technology*, vol. 7, no. 4, hlm. 466–468, Apr 2019, doi: 10.32622/ijrat.742019164.
- [3] D. C. Charmpis, M. C. Phocas, dan P. Komodromos, "Optimized retrofit of multi-storey buildings using seismic isolation at various elevations: assessment for several earthquake excitations," *Bulletin of Earthquake Engineering*, vol. 13, no. 9, hlm. 2745–2768, Sep 2015, doi: 10.1007/s10518-015-9737-y.
- [4] Y. Tsuneki, S. Torii, K. Murakami, dan T. Sueoka, "Middle-Story Isolated Structural System of High-Rise Building," *Journal of Disaster Research*, vol. 4, no. 3, hlm. 229–238, Jun 2009, doi: 10.20965/jdr.2009.p0229.
- [5] K. Yamane, H. Tsubaki, T. Tanaka, dan A. Sumi, "Structures Paper: Isolation Story Structure of Umeda Tower, Osaka, Japan," *Structural Engineering International*, vol. 13, no. 4, hlm. 225–227, Nov 2003, doi: 10.2749/101686603777964351.
- [6] A. Dutta, J. F. Sumnicht, R. L. Mayes, R. O. Hamburger, dan A. Citipitioglu, "An Innovative Application of Base Isolation Technology," dalam *Structures Congress 2008*, Reston, VA: American Society of Civil Engineers, Okt 2008, hlm. 1–13. doi: 10.1061/41000(315)13.
- [7] T. Sueoka, S. Torii, dan Y. Tsuneki, "The Application of Response Control Design Using Middle-Story Isolation System to High-Rise Building," dalam *13th World Conference on Earthquake Engineering*, Vancouver, B.C., Jul 2004. Diakses: 16 Juni 2024. [Daring]. Tersedia pada: [https://www.iitk.ac.in/nicee/wcee/article/13\\_3457.pdf](https://www.iitk.ac.in/nicee/wcee/article/13_3457.pdf)
- [8] H. Chen, H. Xu, Y. Liu, dan X. Ren, "Seismic demand estimation of isolated buildings with nonlinear bearings subjected to linear response spectra," *Journal of Building Engineering*, vol. 67, hlm. 105995, Mei 2023, doi: 10.1016/j.job.2023.105995.
- [9] K. Yang, P. Tan, H. Chen, J. Li, dan J. Tan, "Prediction of nonlinear seismic demand of inter-story isolated systems using improved multi-modal pushover analysis procedures," *Journal of Building Engineering*, vol. 82, hlm. 108322, Apr 2024, doi: 10.1016/j.job.2023.108322.
- [10] V.-T. Nguyen, N.-Q. Vu, dan X.-D. Nguyen, "Application of seismic isolation for multi-story buildings in moderate seismicity areas like Vietnam," *J Phys Conf Ser*, vol. 1706, no. 1, hlm. 012119, Des 2020, doi: 10.1088/1742-6596/1706/1/012119.
- [11] AASHTO, *Guide Specifications for Seismic Isolation Design*, 4 ed. Washington, DC: AASHTO, 2014.
- [12] J. M. Kelly, *Earthquake-Resistant Design with Rubber*, 1 ed. London: Springer London, 1993. doi: 10.1007/978-1-4471-3359-9.
- [13] EN 1337-3, *Structural Bearings - Part 3: Elastomeric bearings*, 3 ed. 2005. Diakses: 16 Juni 2024. [Daring]. Tersedia pada: [https://www.assamrof.com/wp-content/uploads/2018/12/BS-EN-1337-3\\_-1612023707.pdf](https://www.assamrof.com/wp-content/uploads/2018/12/BS-EN-1337-3_-1612023707.pdf)
- [14] N. Septian, G. Turuallo, dan I. K. Sulendra, "Kinerja Portal Struktur Gedung Tahan Gempa dengan Sistem Ganda Menggunakan Metode Pushover Analysis," *REKONSTRUKSI TADULAKO: Civil Engineering Journal on Research and Development*, hlm. 35–42, Feb 2022, doi: 10.22487/renstra.v3i1.405.
- [15] Bhupendra Sharma dan Abhijeet Galatage, "Study of Pushover Analysis of RCC Building with Soft Story at Different Elevations," *International Journal of Innovative Research in Science, Engineering and Technology (IJIRSET)*, vol. 10, no. 6, hlm. 7548–7558, Jun 2021, doi: 10.15680/IJIRSET.2021.1006281.

## How to cite this article:

Rahman A, Fajarwati A N, Sholeh M, Sugiarto A. Pushover Analysis of Harvard Dormitory Thursina International Islamic Boarding School Building with Inter Story Isolated System Modification. *Jurnal Teknologi dan Manajemen*. 2025 January; 6(1):9-18. DOI: 10.31284/j.jtm.2025.v6i1.6283